

ACCESSORIES CATALOG 4.2



**Welding and Cutting Accessories for all
Metalworking Industries.**





Content

■ Content	3
■ Anti-spatter Anti-Spatter-Spray and Anti-Spatter-Spray NF	4
■ Anti-spatter Düsofix	5
■ Anti-spatter Ceramic Spray	6
■ Anti-spatter ABIBLUE NF	8
■ Coolant liquids Conductivity tester	11
■ Coolant liquids BTC & BTC-NF	12
■ Welding accessories Utilities and tools	14
■ Welding accessories Adapter pieces, double nipple and quick couplings	17
■ Welding cable connector system ABIPLUG	20
■ Electrode holders DE 2200 / DE 2300 / DE 2400 / DE 2500	22
■ Gouging torch K10 / K12 / K12 T / K16 / K16 T / K20	24
■ Gouging torch TEAM BINZEL® G 3000 / G 4000	26
■ Gouging electrodes TEAM BINZEL® ABIARC	29
■ Coolant recirculators CR 1000 / CR 1250	30

Anti-spatter

Super Pistolenspray & Super Pistolenspray NF

The classical Anti-Spatter-Spray

ABICOR BINZEL Anti-Spatter-Spray is a special silicon-free formula developed on the basis of environmentally-friendly, solvent-free natural special oils that are not harmful to health, and additives that do not have to be specifically labelled.

The Anti-Spatter-Spray has been successfully used in all sectors of the metalworking industry and is in demand daily in very different areas of application.

- Silicon-free
- Environmentally friendly raw materials as a basis
- Solvent-free



Pos.	Description	Part-No.
1	Anti-Spatter-Spray, 400 ml; 12 pcs.; languages: DE/EN/FR/NL/SV/DA/FI/IT	192.0071
1	Anti-Spatter-Spray, 400 ml; 12 pcs.; languages: CS/SK/PL/HU/HR/SL/SR/EN	192.0107
1	Anti-Spatter-Spray, 400 ml; 12 pcs.; languages: RU/UK/LT/LV/ET/BG/RO	192.0213.1
1	Anti-Spatter-Spray, 400 ml; 12 pcs.; languages: EN/ZH/ES/EL/PT/NO/TR	192.0214.1

Non-flammable anti-spatter-spray for torches and workstations

The newly developed Super Pistolenspray NF is a non-flammable anti-spatter agent for torch and workpiece.

It can be used anywhere, especially where the use of flammable sprays is not possible or even prohibited, such as: in closed rooms, in container and shipbuilding.

Based on an aqueous emulsion of vegetable oils, the new Super Pistolenspray NF contains no hazardous substances and is therefore not subject to any separate safety regulations, neither during transport or storage nor during of use.

Thanks to its neutral behavior towards the welding process and thanks to its corrosion inhibitors, it can also be applied to the gas nozzle of the torch and the workpiece for protection against spatters and corrosion.

- Non flammable according ABICOR BINZEL NF standard
- Silicone-free, wax-free and water-soluble
- Neutral behavior towards the welding process
- Corrosion inhibitors protect equipment and surfaces
- Aspraying behavior optimized for workpiece and gas nozzle
- More usable release agent with the same can size



Pos.	Description	Part-No.
2	Super Pistolenspray NF*, 400 ml, 12 pcs., languages: DE/EN/FR/IT/ES/NL/PT/PL/CS/RU/UK/ZH	192.0315.1

*When used for welding aluminium or special alloys, a welding test should always be carried out beforehand.

Anti-spatter Düsofix

Nozzle protection paste

Düsofix is a spatter protection paste for gas nozzles. Biodegradable, special labeling not required, silicon-free. The metal can enables the hot gas nozzle to be dipped safely into the Düsofix – even directly after the welding process. The spatter adhesion is reduced by the protective film.

- Silicon-free
- Special labelling not required
- Can also be used on hot gas nozzles



Pos.	Description	Part-No.
3	Düsofix, 300 g; 12 pcs.; languages: DE/EN/FR	192.0058
3	Düsofix, 300 g; 12 pcs.; languages: CS/SK/PL/RO/BG	192.D032
3	Düsofix, 300 g; 12 pcs.; languages: RU/HU/LT/LV/ET	192.D033
3	Düsofix, 300 g; 12 pcs.; languages: ES/IT/PT/EL/TR	192.0224.1

Anti-spatter Ceramic Spray

Premium anti-spatter-spray for torches

ABICOR BINZEL Ceramic Spray is resistant to high temperatures and provides long-term protection from welding spatter adhesions on gas nozzle and contact tips, and on all welding process fixtures. ABICOR BINZEL Ceramic Spray increases system availability and lowers ongoing maintenance costs. It is also perfectly suitable for automated applications with long welding processes.

After spraying, a white ceramic protective film is formed that is resistant to high temperatures. Thanks to the extremely short drying time of approx. 5 seconds, the welding process can be started immediately.

- Silicone-free
- Very high ceramic content – wide coverage
- Lowers ongoing maintenance costs
- Increases system availability
- Excellent coating adhesion
- High abrasion resistance
- Very short drying time (approx. 5 seconds)
- For all MIG/MAG torches
- For all processes



**ABICOR BINZEL
Ceramic Spray**



Pos.	Description	Part-No.
1	Ceramic Spray, 400 ml; 12 pcs.; languages: DE/EN/FR/NL/ES/PT/IT/SV	192.0228.1
1	Ceramic Spray, 400 ml; 12 pcs.; languages: RU/CS/SK/PL/LT/LV/ET/EN	192.0229.1
1	Ceramic Spray, 400 ml; 12 pcs.; languages: EN/FI/SV/NO/DA/TR/ZH/EL	192.0242.1

**Ceramic
Coating Cap**



The Ceramic Coating Cap was developed specially for ABICOR BINZEL Ceramic Spray. The contact tip as well as the tip of the gas nozzle and its interior can be optimally protected in a few seconds from adhering welding spatter with the Ceramic Coating Cap.

- Cost savings through lower consumption
- Protects the welder and the environment
- Time savings through better handling
- Optimum wetting of the gas nozzle
- Can be reused several times

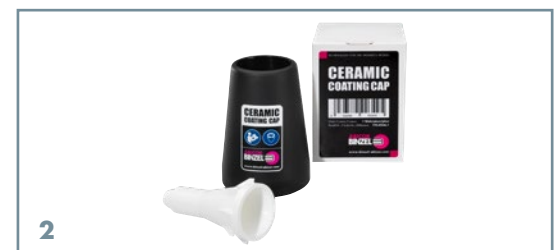

Pos.	Description	Part-No.
2	Ceramic Coating Cap; 10 pcs.	192.0256.10

Anti-spatter ABIBLUE NF

Welding spatter gets the blues!

ABIBLUE NF does away with welding spatter adhesions on the workpiece in a particularly effective way and thus saves time and money. It contains a blue colour indicator that shows the welder immediately whether the workpiece is covered with a separating agent – naturally without influencing the welding process.

Usable for all relevant welding methods, as well as for laser and plasma cutting. This simplifies handling in larger operations with different welding and cutting processes.

Safety for subsequent coating/painting/galvanising was ensured in cooperation with an independent testing institution. In addition, there is no increased hydrogen input with aluminium welding – another quality feature of ABIBLUE NF.

This spatter protection variant is particularly environmentally friendly through the use of sustainable raw materials.

The advantages of ABIBLUE NF

- Non-flammable – satisfies the ABICOR BINZEL NF standard
- Special labeling not required in accordance with GHS/CLP
- Easily biodegradable
- Can be washed off with water
- Silicon-free
- Colour indicator – optimal detection of workpiece wetting
- Suitable for welding and laser cutting applications
- Capability of being welded over confirmed by an independent testing institution
- No adverse effects with subsequent coating/painting/galvanising if standard pre-treatment methods are complied with
- Frost-resistant



„ABICOR BINZEL® NF-Standard“

Products from ABICOR BINZEL that have the abbreviation „NF“ (non-flammable) in their name have passed practical tests developed by ABICOR BINZEL especially for welding technology.

The standard defined by ABICOR BINZEL for NF products goes further than the provisions of the GHS and of the CLP Regulation on the classification of the flammability of an NF product and covers a broad range of standard combinations of active shielding gases,

extremely different workpieces and different welding processes.

Only products that have passed all the tests without igniting may show the ABICOR BINZEL NF designation. In addition to the „NF“ in the name, products are also marked with a stamp.

The ABICOR BINZEL NF standard provides more safety for welders and companies.



**Detecting what will not
ignite even faster:
the stamp for NF products
from ABICOR BINZEL**

ABIBLUE NF
anti-spatter-
emulsion



Pos.	Description	Part-No.
1	ABIBLUE NF anti-spatter-emulsion, 5 litre canister; languages: DE/EN/FR/IT/RU/UK	192.0238.1
2	ABIBLUE NF anti-spatter-emulsion, 10 litre canister; languages: DE/EN/FR/IT/RU/UK	192.0239.1
3	ABIBLUE NF anti-spatter-emulsion, 20 litre canister; languages: DE/EN/FR/IT/RU/UK	192.0240.1
not ill.	ABIBLUE NF anti-spatter-emulsion, 200 litre barrel*; languages: DE/EN/FR/IT/RU/UK	192.0241.1
4	Outlet tap for 20 litre canister; 5 pcs.	192.0191.5

* Can be used for at least 6 months without remixing if stored and transported frost-free.
In order to guarantee maximum durability, the barrels are not in stock, but the delivery time is only approx. 2 weeks.

Anti-spatter ABIBLUE NF

ABIBLUE NF spray bottles

The sprays have spray heads specially designed for ABIBLUE NF and thus ensure an optimum spraying pattern. The spray head can be set to the required spraying pattern before use, and the workpiece can be evenly sprayed and wetted. Suitable for use with ABIBLUE NF anti-spatter-emulsion.

The metal spray bottle is our robust solution for keeping ABIBLUE NF close to the process. Thanks to its solid metal body, it is insusceptible to heat and welding spatter.



A plastic spray bottle is available as an alternative to the metal spray bottle. This does not require pressure compensation and is thus leak proof.



Pos.	Description	Part-No.
1	Metal spray bottle, without contents, 400 ml; 12 pcs.	192.0163
2	Hand spray pump for metal spray bottle; 1 pc.	192.0164
3	Plastic spray bottle, without contents, 500 ml; 15 pcs.	192.0254.15

„ABICOR BINZEL® NF-Standard“

Products from ABICOR BINZEL that have the abbreviation „NF“ (non-flammable) in their name have passed practical tests developed by ABICOR BINZEL especially for welding technology.

The standard defined by ABICOR BINZEL for NF products goes further than the provisions of the GHS and of the CLP Regulation on the classification of the flammability of an NF product and covers a broad range of standard combinations of active shielding gases,

extremely different workpieces and different welding processes.

Only products that have passed all the tests without igniting may show the ABICOR BINZEL NF designation. In addition to the „NF“ in the name, products are also marked with a stamp.

The ABICOR BINZEL NF standard provides more safety for welders and companies.



**Detecting what will not
ignite even faster:
the stamp for NF products
from ABICOR BINZEL**

Coolant liquids

Conductivity tester

Primo 5

Low conductivity of the coolant in liquid cooled welding and cutting equipment has been shown to increase the lifetime of the hose package, torch and cooling unit and should therefore be checked at regular intervals.

The new conductivity tester Primo 5 is ideally suited for checking the conductivity and, thanks to its compact design, allows a faster and less complicated measurement than its predecessor.

Its long, rugged probe requires low maintenance while still ensuring accurate measurement. The measured value is easy to read via the large display. Temperature compensation is automatic via integrated temperature sensor and the calibration is done automatically via a special calibration liquid.



Pos.	Description	Part-No.
4	Conductivity tester Primo 5	514.0062.1
	Calibration liquid bottle 230 ml	514.0311.1



Recommended maximum conductivity:

MIG/MAG	350 $\mu\text{S}/\text{cm}$
TIG	250 $\mu\text{S}/\text{cm}$
Plasma	30 $\mu\text{S}/\text{cm}^*$

* applies to products from ABICOR BINZEL, for competitor products, the manufacturer's specifications are to be observed!

Technical data:

Range:	0 to 1999 $\mu\text{S}/\text{cm}$
Resolution:	1 $\mu\text{S}/\text{cm}$
Accuracy:	$\pm 2\%$ of the display
Calibration:	Automatic with calibration liquid (1413 $\mu\text{S}/\text{cm}$)
Temperature compensation:	Automatic between 0 and 50°C
Battery type/lifetime:	2 x 1.5 V, approx. 200 hours of continuous use
Automatic shutdown:	After 5 min.
Dimension:	180 x 50 x 25 mm
Weight:	50 g

Coolant liquids

BTC & BTC-NF

Coolants for all welding and cutting systems

Liquid cooled torches require special coolants. These should have very good cooling properties, low electrical conductivity and in addition good storage properties. ABICOR BINZEL BTC coolants satisfy these requirements reliably, ensure optimal cooling of liquid cooled welding and cutting torches and thus provide perfect protection for the complete cooling system.

- Optimal cooling of torches
- Long life in the cooling system
- Prevents a rapid increase in the electrical conductivity – electrical corrosion on metal parts is considerably reduced
- The complete cooling system is protected from blockages and consequential damage
- Suitable for all welding and cutting systems

BTC-15



- Very low conductivity value of <math>< 4\mu\text{S}/\text{cm}</math>.
- Frost-proof up to -12°C
- Silicone-free
- pH value: 6



Pos.	Description	Part-No.
1	BTC-15, 5 litre canister; languages: DE/EN/FR/ES/CS/SK/PL/RU	192.0110
2	BTC-15, 20 litre canister; languages: DE/EN/FR/ES/CS/SK/PL/RU	192.0111
3	Outlet tap for 20 litre canister; 5 pcs.	192.0191.5
not ill.	BTC-15, 200 litre barrel; languages: DE/EN/FR/CS/PL/RU	192.0112
4	Spigot for 200 litre barrels; 1 pc.	192.0109

“ABICOR BINZEL® NF-Standard”

Products from ABICOR BINZEL that have the abbreviation „NF“ (non-flammable) in their name have passed practical tests developed by ABICOR BINZEL especially for welding technology.

The standard defined by ABICOR BINZEL for NF products goes further than the provisions of the GHS and of the CLP Regulation on the classification of the flammability of an NF product and covers a broad range of standard combinations of active shielding gases,

extremely different workpieces and different welding processes.

Only products that have passed all the tests without igniting may show the ABICOR BINZEL NF designation. In addition to the „NF“ in the name, products are also marked with a stamp.

The ABICOR BINZEL NF standard provides more safety for welders and companies.



**Detecting what will not ignite even faster:
the stamp for NF products
from ABICOR BINZEL**

BTC-20 NF



- Very low conductivity value of $< 4\mu\text{S}/\text{cm}$.
- Non-flammable - conforms to the ABICOR BINZEL NF standard
- Uncomplicated storage - non-flammable product
- Frost-proof up to -17°C
- Silicone-free
- pH value: 6



Pos.	Description	Part-No.
5	BTC-20 NF, 5 litre canister; languages: DE/EN/FR/ES/CS/SK/PL/RU	192.0265.1
5	BTC-20 NF, 5 litre canister; languages: DE/FR/NL/TR/NO/DA/PT/SV	192.0266.1
6	BTC-20 NF, 20 litre canister; languages: DE/EN/FR/ES/CS/SK/PL/RU	192.0267.1
6	BTC-20 NF, 20 litre canister; languages: DE/FR/NL/TR/NO/DA/PT/SV	192.0268.1
7	Outlet tap for 20 litre canister; 5 pcs.	192.0191.5
not ill.	BTC-20 NF, 200 litre barrel; languages: DE/EN/FR/CS/PL/RU	192.0269.1
8	Spigot for 200 litre barrels; 1 pc.	192.0109

BTC-50 NF



- Very low conductivity value of $< 4\mu\text{S}/\text{cm}$.
- Non-flammable - conforms to the ABICOR BINZEL NF standard
- Uncomplicated storage - non-flammable product
- Frost-proof up to -45°C
- Silicone-free
- pH value: 6



Pos.	Description	Part-No.
9	BTC-50 NF, 5 litre canister; languages: DE/EN/FR/ES/CS/SK/PL/RU	192.0175.1
9	BTC-50 NF, 5 litre canister; languages: DE/FR/NL/TR/NO/DA/PT/SV	192.0260.1
10	BTC-50 NF, 20 litre canister; languages: DE/EN/FR/ES/CS/SK/PL/RU	192.0176.1
10	BTC-50 NF, 20 litre canister; languages: DE/FR/NL/TR/NO/DA/PT/SV	192.0261.1
11	Outlet tap for 20 litre canister; 5 pcs.	192.0191.5
not ill.	BTC-50 NF 200 litre barrel; languages: DE/EN/FR/CS/PL/RU	192.0177.1
12	Spigot for 200 litre barrels; 1 pc.	192.0109

Welding accessories

Utilities and tools

Special pliers and wire cleaning sets



- 1 Special pliers (FIX)**
 No. 1 for gas nozzles NS 12-15 mm Part-No. 193.0013
 No. 2 for gas nozzles NS 15-18 mm Part-No. 193.0014



- 2 Wire cleaning set red** for steel (set)
red for steel (25 pcs.) Part-No. 193.0001.1
 Part-No. 193.0003.25



- 3 Wire cleaning set white** for Al (set)
white for Al (25 pcs.) Part-No. 193.0002.1
 Part-No. 193.0004.25



- 4 Clamp**
 (12 pcs.) Part-No. 193.0007

Handy-supports, sharpener, hose cutters and gas flow meters



- 5 TIG handy-support (FIX)**
 without magnet base Part-No. 193.0019



- 6 MIG handy-support (FIX)**
 without magnet base Part-No. 193.0018

Magnet base (not ill.) Part-No. 193.0023



- 7 Sharpener**
 for plastic liners Part-No. 191.0064

- 8 Hose cutter** Part-No. 191.0062.1



- 9 Gas flow meter** Part-No. 191.0003

Accessories case



- 10 Accessories case**
 small Part-No. 192.0066
 big Part-No. 192.0069

Special wrenches

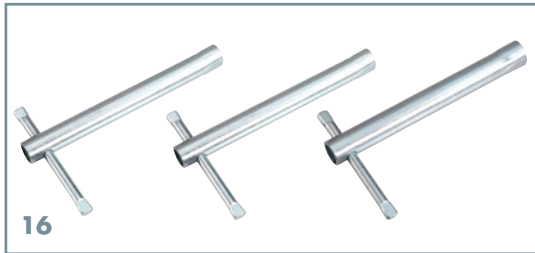
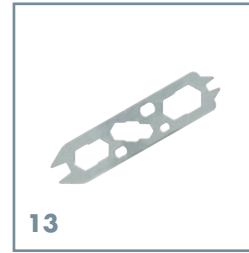
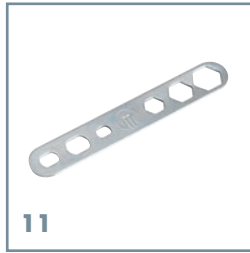

11 Wrench
Standard

Part-No. 191.0001

12 Multiple wrench
(10 pcs.)

Part-No. 191.0015

13 Wrench
for ABIMIG®

Part-No. 191.D045

14 Universal wrench

Part-No. 750.0125

15 Electrode wrench

Part-No. 743.0064

16 Socket wrench (L=120 mm)

SW 6

Part-No. 191.0103

SW 8

Part-No. 191.0102

SW 10

Part-No. 191.0104

Welding accessories

Utilities and tools

Belt clip



17 ABI-CLIP

Belt clip for easy routing and strain relief of air cooled BIKOX® cables (Ø 14-25 mm).

Part-No. 191.0141.1

Welding accessories

Adapter pieces, double nipple and quick couplings

Adapter pieces



Description	Part-No.
Adapter piece M12x1 - G3/8"	710.0003
Adapter piece M12x1 - G1/4"	710.0004
Adapter piece M10x1 - G1/8"	710.0005
Adapter piece G1/8" - G1/4"	710.0006
Adapter piece G1/8" - G3/8"	710.0007
Adapter piece G1/8" - G3/8" 24 G	710.0008
Adapter piece M12x1 - G1/8"	710.0009
Adapter piece G3/8" - G1/4"	710.0025
Adapter piece M12x1 - M10x1	710.0027
Adapter piece M10x1 - M12x1	710.0028
Adapter piece G1/8" - M12x1	710.0034
Adapter piece M14x1 AG - 1/4IG	710.0035
Adapter piece M12x1 AG - 7/8"-14G LH A	710.0037

Double nipple

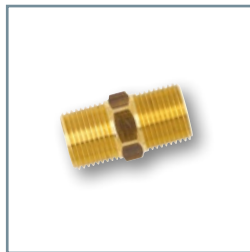

Description	Part-No.
Double nipple G1/8" AG / M12x1 AG SW 12 (MS)	710.0015
Double nipple G1/8" AG / G1/8" AG SW 12 (MS)	710.0016
Double nipple M12x1 AG / M12x1 AG SW 12 (MS)	710.0017
Double nipple G1/4" AG / G1/4" AG SW 14 (MS)	710.0018
Double nipple G3/8" AG / G3/8" AG SW 17 (MS)	710.0019
Double nipple M10x1 AG / M10x1 AG SW 10 (MS)	710.0020

Quick couplings



1



2



3

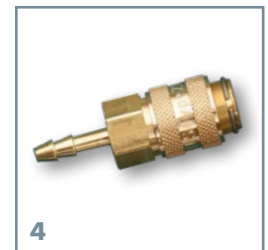

4



5



6



7



8

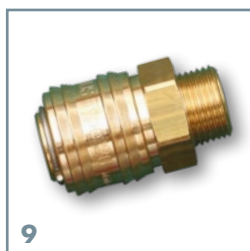

9



10



11



12

Welding accessories

Adapter pieces, double nipple and quick couplings

Quick couplings

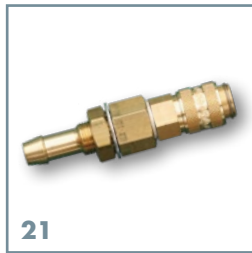
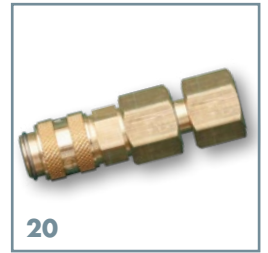
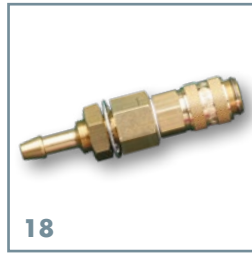
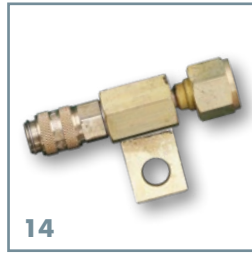

Pos.	Description	Part-No.
1	Quick coupling DN 2.7 G1/8" AG	177.0001
2	Quick coupling DN 5 G1/8" IG	177.0002
3	Quick coupling DN 5 G1/8" AG	177.0003
4	Quick coupling DN 5; nozzle Ø = 4 mm	177.0007
5	Quick coupling DN 6; nozzle Ø = 6 mm	177.0008
6	Quick coupling DN 2.7; nozzle Ø = 4 mm	177.0009
7	Quick coupling DN 7.2; nozzle Ø = 6 mm	177.0010
8	Quick coupling DN 5; nozzle Ø = 6 mm; self-locking	177.0016.10
9	Quick coupling G3/8" AG	177.0012
10	Quick coupling DN 5 G1/8" AG; red	177.0013
11	Quick coupling DN 5 G1/8" AG; blue	177.0014
12	Quick coupling DN 5; nozzle Ø = 8 mm	177.0015.1
13	Quick coupling DN 5 G1/4" IG	501.0158
14	Quick coupling DN 5 G3/8" IG with lug	501.0163
15	Quick coupling DN 5 M12x1 IG	501.0176
16	Quick coupling DN 5 5/8" - 18G UNF-LH AG	501.0188
17	Quick coupling DN 5 G3/8" IG	501.0189
18	Quick coupling DN 5; nozzle Ø = 8 mm	501.0190
19	Quick coupling DN 5 1/2" IG	501.0191
20	Quick coupling DN 5 M12x1,5 IG	501.0194
21	Quick coupling DN 5; nozzle Ø = 10 mm	501.0195
22	Quick coupling DN 5 7/8" - 14G UNF IG	501.0196
23	Quick coupling DN 5 M14x1 IG	501.0197
24	Quick coupling DN 5; nozzle Ø = 6.5 mm	501.0204
25	Quick coupling DN 2.7; nozzle Ø = 6.5 mm	501.0230
26	Quick coupling DN 5; nozzle Ø = 6 mm	501.0270
27	Quick coupling DN 5 5/8" - 18G UNF IG	501.1795
28	Plug-in nipple DN 5; Ø = 6 mm; self-locking	501.2318
29	Quick coupling DN 5; nozzle Ø = 6.5 mm; red	501.2403
30	Quick coupling DN 5; nozzle Ø = 6.5 mm; blue	501.2404
31	Quick coupling DN 5; nozzle Ø = 6 mm	560.0017
32	Quick coupling DN 7.2 cpl.; Masterliner	783.5207.1
33	Assembly kit WK43; for 2 connectors	850.0235
34	Quick coupling DN 5 1/4" AG	850.0263

Welding cable connector system

ABIPLUG

Plug and weld! ABIPLUG – the reliable connection.

The new range of **ABIPLUG** welding cable connectors from **ABICOR BINZEL** – designed for safe and effective current transfer in arc welding technology – guarantees maximum operating safety for the equipment and the user. Available as either panel socket / cable plug combination or as panel plug / cable socket combination.

The advantages:

- Safe and quick connection – highest twist resistance due to the revolutionary “square end-block-system” by ABICOR BINZEL
- High flash-over resistance – for maximum machine protection
- Easy mounting, optimal connection and excellent power transmission
- Compatible with all commercially available makes – can be built out of metal or plastic panels
- Corresponds to EN-standard EN 60 974-12 – the new EN-standard



Technical data

Welding cable connector system

Type	Current (A)	Cable (mm ²)	Mount-Ø (mm)
*10-25	125	up to 10	20.5
*10-25	150	10–16	20.5
*10-25	200	16–25	20.5
*35-50	250	25–35	30.5
*35-50	300	35–50	30.5
*50-70	400	50–70	30.5
*70-95	500	70–95	30.5

* = **ABI-CM** / **ABI-IF** or **ABI-CF** / **ABI-IM**

ABI-CM (Cable **M**ale) = Welding cable plug

ABI-CF (Cable **F**emale) = Welding cable socket

ABI-IM (Insert **M**ale) = Panel mounted plug

ABI-IF (Insert **F**emale) = Panel mounted socket



Panel sockets

1	ABI-IF 10-25	Part-No.	511.0304
2	ABI-IF 35-50	Part-No.	511.0314
3	ABI-IF 50-70	Part-No.	511.0330
4	ABI-IF 70-95	Part-No.	511.0309

Cable plugs

5	ABI-CM 10-25	Part-No.	511.0305
6	ABI-CM 35-50	Part-No.	511.0315
7	ABI-CM 50-70	Part-No.	511.0331
8	ABI-CM 70-95	Part-No.	511.0342



Panel plugs

9	ABI-IM 10-25	Part-No.	511.0306
10	ABI-IM 35-50	Part-No.	511.0316
11	ABI-IM 50-70	Part-No.	511.0332
12	ABI-IM 70-95	Part-No.	511.0320

Cable sockets

13	ABI-CF 10-25	Part-No.	511.0303
14	ABI-CF 35-50	Part-No.	511.0313
15	ABI-CF 50-70	Part-No.	511.0329
16	ABI-CF 70-95	Part-No.	511.0340



Electrode holders

DE 2200 / DE 2300 / DE 2400 / DE 2500

The tough classics ...

The electrode holders are used for manual electrode welding. Manual electrode welding is one of the oldest and most proven arc welding operations that are still applied today. It stands out due to relatively low investment needs as well as its universal application possibilities. KURT HAUFER electrode holders "DE" are million-fold proven for decades and due to their extremely tough construction they are the optimum tool for the "outdoor professional" – amongst others in shipyards, pipeline construction and bridge building.

Besides the traditional version for connection via cable shoe the new "K"-series offers the possibility of direct crimp connection with the bare welding cable.

Special features:

- High-tensile, heat insulated handle
- Mechanical and thermal heavy-duty insulating material
- Safe electrode voltage in four chip flutes
- Big electrode and welding cable connection area



Technical data

Type	Rating		Electrodes-Ø	Welding cable	Connection bolt ²
	at 60% duty cycle	at 35% duty cycle			
DE 2200 / K ¹	200 A	250 A	2.0-4.0 mm	25 / 35 mm ²	M8
DE 2300 / K ¹	300 A	400 A	2.0-6.3 mm	35 / 70 mm ²	M8
DE 2400 / K ¹	400 A	500 A	4.0-8.0 mm	50 / 95 mm ²	M10
DE 2500 / K ¹	500 A	600 A	4.0-10.0 mm	70 / 120 mm ²	M10

¹ K=Clamp-connection via ferrule

² for cable shoe

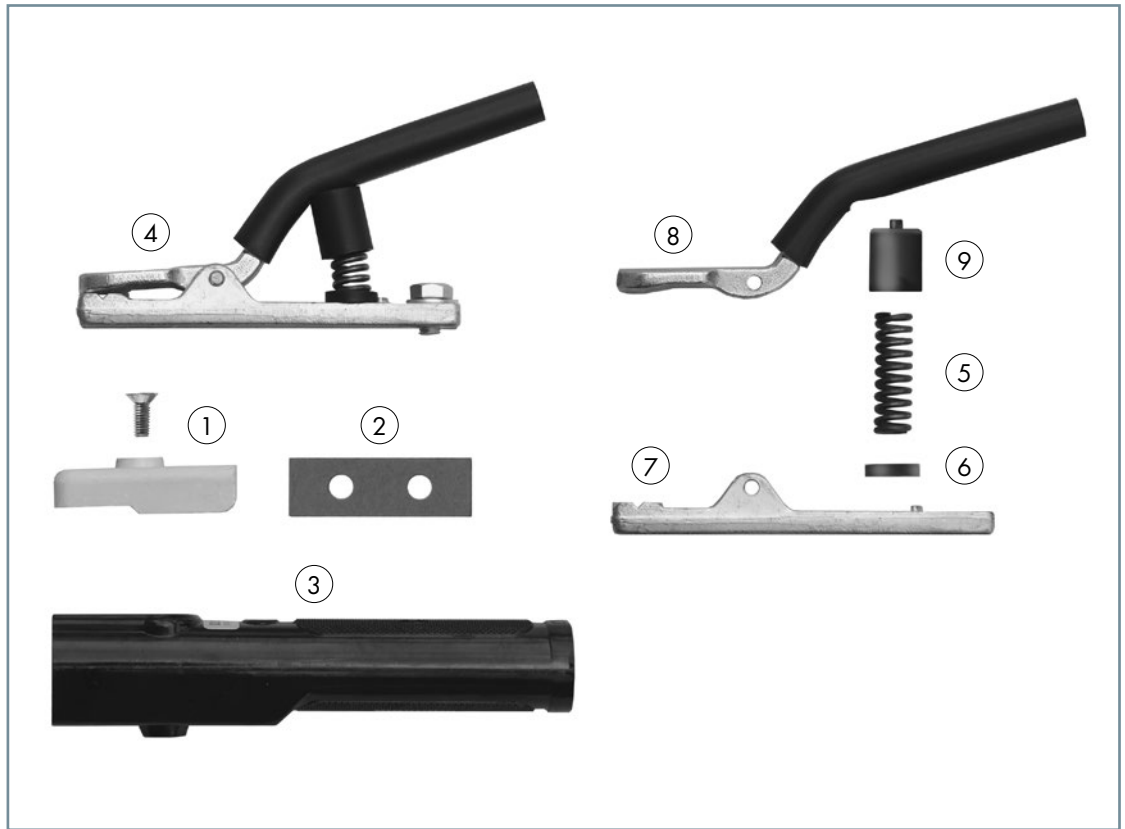

Electrode holder cpl.

Type	Part-No.
Electrode holder DE 2200	512.D060
Electrode holder DE 2300	512.D070
Electrode holder DE 2400	512.D080
Electrode holder DE 2500	512.D090
Electrode holder DE 2200 K	512.D470
Electrode holder DE 2300 K	512.D471
Electrode holder DE 2400 K	512.D472
Electrode holder DE 2500 K	512.D480

Wear parts

Pos.	Description	Part-No.			
		DE 2200 / K	DE 2300 / K	DE 2400 / K	DE 2500 / K
1	Insulating flange (2 pcs.)	512.D021	512.D031	512.D041	512.D091
2	Insulating plate	-	512.D032	512.D032	512.D032
3	Handle	512.D483.1	512.D486.1	512.D145	512.D145
4	Front part	512.D268	512.D384	512.D272	512.D274
not ill.	Front part "K"	512.D473	512.D474	512.D475	512.D481
5	Pressure spring	512.D025	512.D035	512.D035	512.D035
6	Cap (5 pcs.)	512.D026	512.D036	512.D036	512.D036
7	Bottom part	512.D276	512.D278	512.D280	512.D282
not ill.	Bottom part "K"	512.D416	512.D418	512.D422	512.D424
8	Lever	512.D028	512.D201	512.D048	512.D098
9	Insulating cap	512.D029	512.D039	512.D039	512.D039
not ill.	Ferrule "K"	511.0048	511.0065	511.0104	511.0104

Gouging torch

K10 / K12 / K12 T / K16 / K16 T / K20

Reliable and safe ...

The original KURT HAUFE gouging torch is used for gouging, joint preparation, removing of pores and cracks, chamfering, cutting, surface treatment and hole piercing at all metals. They stand out due to their reliability and safety.

Special features:

- Oval, rugged, heat insulated handle
- Regulation of compressed air via rotary valve
- High air consumption
- High flex cable
- T-version with swivel joint
- Turnable nozzle suitable for round and flat electrodes



Technical data

Type	Rating	Duty cycle	Round electrode-Ø	Flat electrode		Compr. air max.	Compr. air connection
				width (mm)	thickness (mm)		
K10	500 A	60%	4-10 mm	15 / 20	4	10 bar	3/8"-18 NPT
K12 / T	600 A	60%	4-12 mm	15 / 20	4-5	10 bar	3/8"-18 NPT
K16 / T	1000 A	60%	8-16 mm	15 / 20 / 25	4-5	10 bar	3/8"-18 NPT
K20	1500 A	60%	8-19 mm	15 / 20 / 25	4-5	10 bar	3/8"-18 NPT

Gouging torch cpl.

Type		Part-No.	
		2.1 m	3.0 m
Gouging torch K10	cpl. with cable assembly	516.D124	516.D001
Gouging torch K12	cpl. with cable assembly	516.D125	516.D002
Gouging torch K12 T	cpl. with cable assembly	516.D154	516.D142
Gouging torch K16	cpl. with cable assembly	516.D126	516.D003
Gouging torch K16 T	cpl. with cable assembly	516.D155	516.D150
Gouging torch K20	cpl. with cable assembly	-	516.D167.1

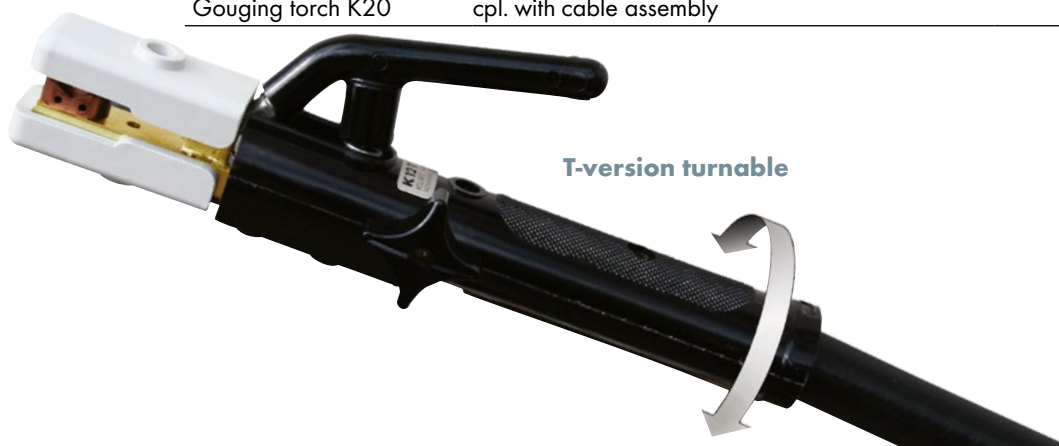

T-version turnable

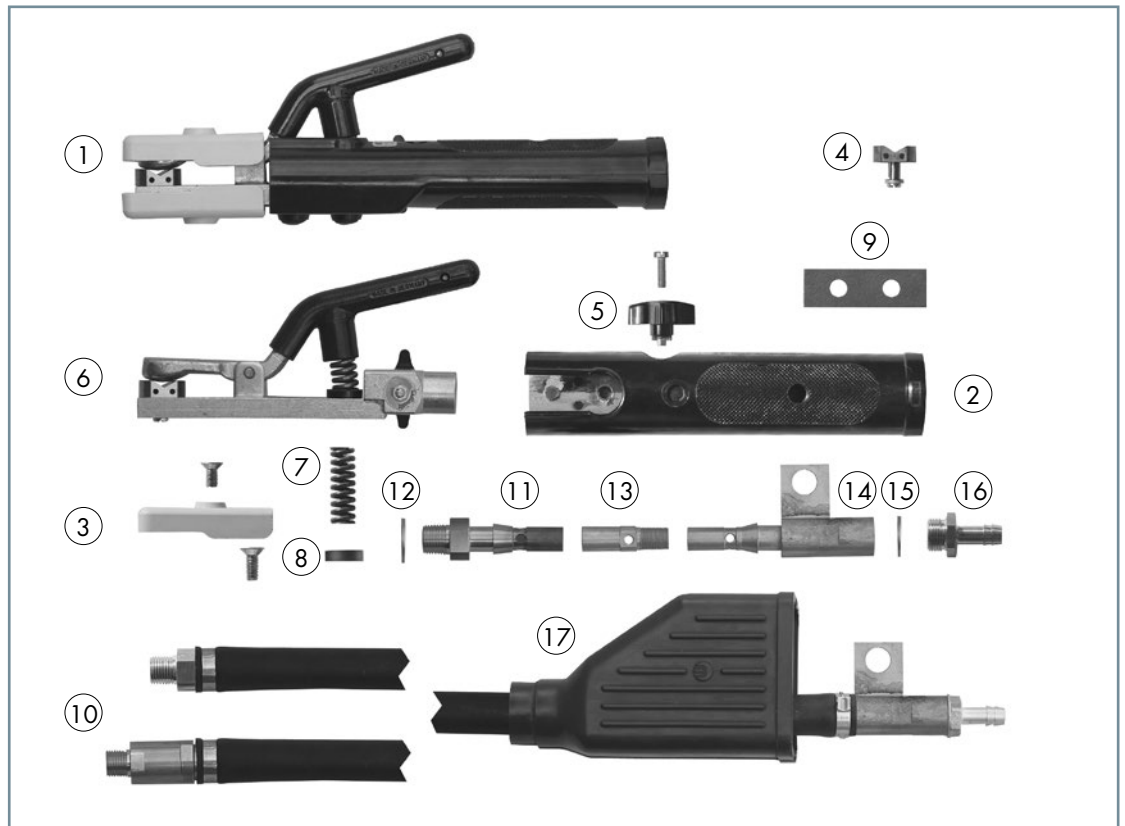

Wear parts

Pos.	Description	Part-No.					
		K10	K12	K12 T	K16	K16 T	K20
1	Gouging torch w/o tube cable	516.D028	516.D028	516.D028	516.D040	516.D040	516.D195.1
2	Handle	516.D011	516.D011	516.D011	516.D011	516.D011	516.D011
3	Insulating flange (2 pcs.)	512.D091	512.D091	512.D091	516.D042	516.D042	516.D196.2
4	Nozzle for round electrodes (5 pcs.)	516.D026	516.D026	516.D026	516.D044	516.D044	516.D044
5	Cross handle	516.D012	516.D012	516.D012	516.D012	516.D012	516.D012
6	Front part cpl.	516.D027	516.D027	516.D027	516.D041	516.D041	516.D168.1
7	Pressure spring	516.D013	516.D013	516.D013	516.D013	516.D013	516.D013
8	Cap (5 pcs.)	512.D036	512.D036	512.D036	512.D036	512.D036	512.D036
9	Insulating plate	512.D032	512.D032	512.D032 ¹	512.D032	512.D032 ¹	512.D032
10	Tube cable cpl. for 2.1 m	516.D127	516.D129	516.D156	516.D130	516.D157	-
	Tube cable cpl. for 3.0 m	516.D050	516.D018	516.D143	516.D048	516.D151	516.D197.1
11	Connection piece	516.D051	516.D022	-	516.D043	-	516.D043
12	Space ring (10 pcs.)	516.D053	516.D053	516.D053	516.D053	516.D053	516.D053
13	Inside connection	-	516.D160	516.D160	516.D161	516.D161	516.D161
14	Connection piece	516.D135	516.D158	516.D158	516.D158	516.D158	516.D158
15	Space ring (10 pcs.)	001.D170	001.D170	001.D170	001.D170	001.D170	001.D170
16	Threaded nozzle	001.D171	001.D172	001.D172	001.D172	001.D172	001.D172
17	Insulating joint	516.D134	516.D134	516.D134	516.D134	516.D134	516.D134
not ill.	Special hose for 2.1 m	516.D128	516.D131	-	516.D131	-	-
	Special hose for 3.0 m	516.D055	516.D021	-	516.D021	-	516.D021
not ill.	Flat nozzle 15/20 (5 pcs.)	516.D023	516.D023	516.D023	516.D023	516.D023	516.D023
not ill.	Flat nozzle 15/20 15 (5 pcs.)	516.D024	516.D024	516.D024	516.D024	516.D024	516.D024
not ill.	Flat nozzle 15/20 20 (5 pcs.)	516.D025	516.D025	516.D025	516.D025	516.D025	516.D025
not ill.	Flat nozzle 15/20 25 (5 pcs.)	-	-	-	516.D045	516.D045	516.D045

¹ K12 T and K16 T require 2 insulating plates (512.D032) each.

Gouging torch TEAM BINZEL®

G 3000 / G 4000

Rugged and easy to handle ...

The TEAM BINZEL® gouging torches G 3000 and G 4000 are safe and easy to handle. They are designed to be used for gouging, weld seam preparing, gouging out of blowholes and cracks, chamfering, cutting, surface resurfacing and keyhole cutting for all common materials.

Special features:

- Rugged and heat resistant handle
- Turnable nozzle suitable for round and flat electrodes
- High air consumption
- High flex cable
- Swivel joint



Technical data

Type	Rating	Duty cycle	Nom. air pressure	Nom. volume flow	Connection air supply
G 3000	max. 600 A	60%	7 bar	approx. 0.60 m ³ / min.	3/8"-18 NPT
G 4000	max. 1000 A	35%	7 bar	approx. 0.70 m ³ / min.	3/8"-18 NPT



**Gouging torch
TEAM BINZEL®
G 3000**



Type	Part-No.
Gouging torch TEAM BINZEL® G 3000 (torch only)	516.0001
Gouging torch TEAM BINZEL® G 3000 cpl. with cable assembly (length = 2.1 m)	516.0002
Gouging torch TEAM BINZEL® G 3000 cpl. with cable assembly (length = 3.0 m)	516.0003
Cable assembly, length = 2.1 m	516.0004
Cable assembly, length = 3.0 m	516.0005

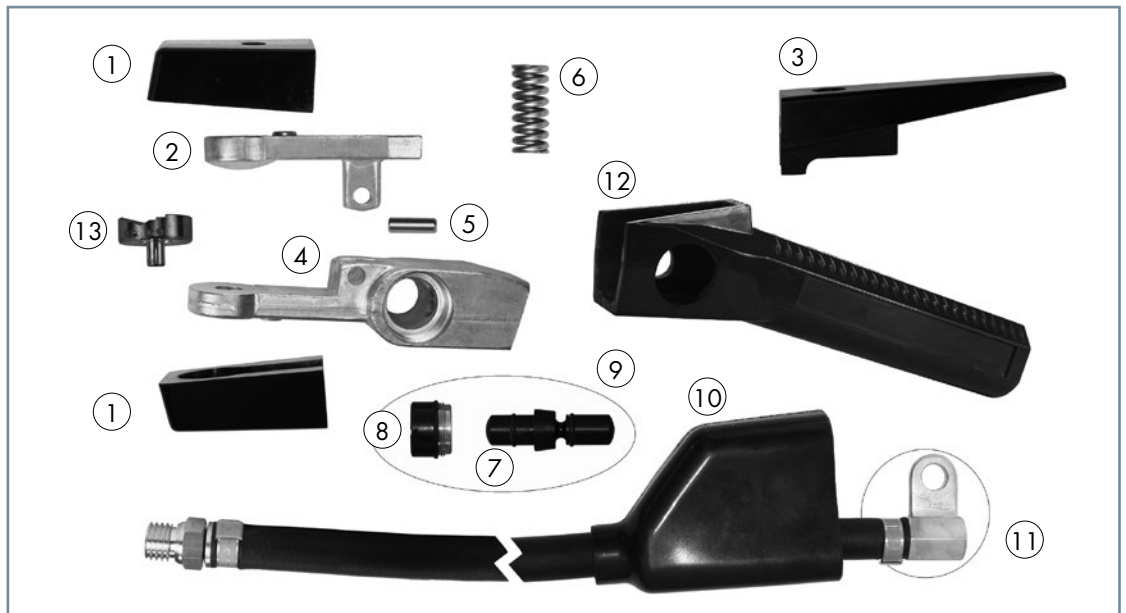

Wear parts

Pos.	Description	Part-No.
1	Insulator set (2 pcs.)	516.0006
2	Lever top part	516.0007
3	Lever	516.0008
4	Torch body	516.0009
5	Bolt	516.0010
6	Pressure spring	516.0011
7	Slider	516.0012
7	Slider with O-ring	516.0013
7	O-ring (2 pcs.)	516.0014
8	Fastening nut	516.0015
9	Valve cpl.	516.0016
10	Insulating part	516.0017
11	Connector	516.0018
12	Handle	516.0019
13	Flat nozzle	516.0020

Gouging torch TEAM BINZEL®

G 3000 / G 4000

Gouging torch
TEAM BINZEL®
G 4000



Type	Part-No.
Gouging torch TEAM BINZEL® G 4000 (torch only)	516.0022
Gouging torch TEAM BINZEL® G 4000 cpl. with cable assembly (length = 2.1 m)	516.0023
Gouging torch TEAM BINZEL® G 4000 cpl. with cable assembly (length = 3.0 m)	516.0024
Cable assembly, length = 2.1 m	516.0025
Cable assembly, length = 3.0 m	516.0026

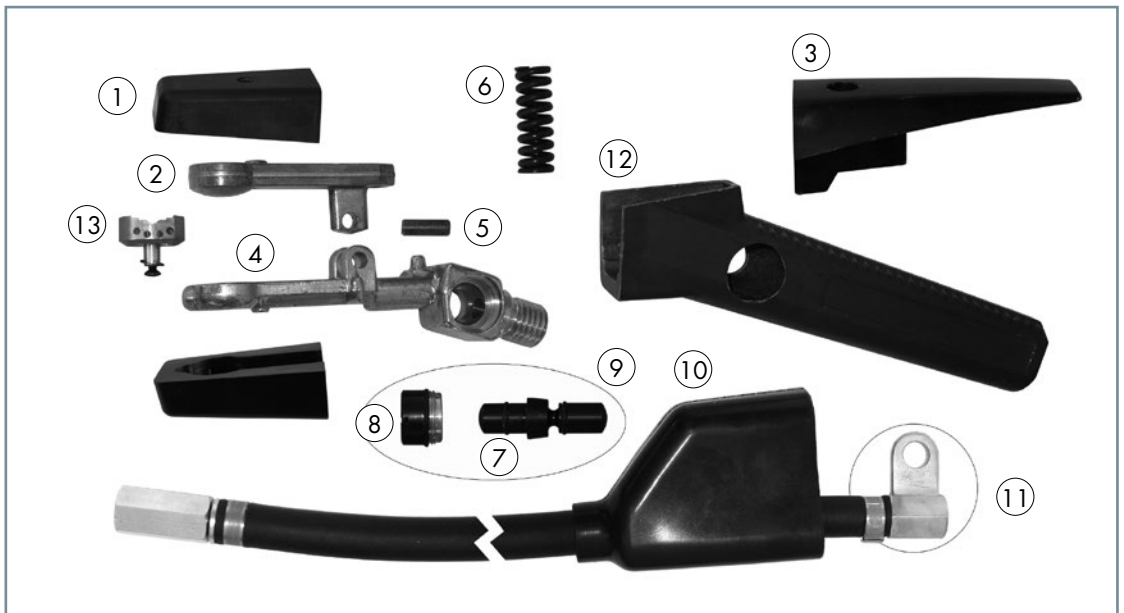

Wear parts

Pos.	Description	Part-No.
1	Insulator set (2 pcs.)	516.0027
2	Lever top part	516.0028
3	Lever	516.0029
4	Torch body	516.0030
5	Bolt	516.0031
6	Pressure spring	516.0032
7	Slider	516.0012
7	Slider with O-ring	516.0013
7	O-ring (2 pcs.)	516.0014
8	Fastening nut	516.0015
9	Valve cpl.	516.0016
10	Insulating part	516.0017
11	Connector	516.0018
12	Handle	516.0033
13	Flat nozzle	516.0034

Gouging electrodes TEAM BINZEL®

ABIARC

Pure efficiency

TEAM BINZEL® gouging electrodes are made of artificial graphite and have a pure copper coating. The gouging electrodes are available in the variety of shapes and diameters to meet the needs of various applications.

Special features:

- Pure copper coated – good electric conductivity
- High density (made of artificial graphite) – high metal removal rate
- Less consumption of electrodes – cost reduction
- Constant quality – for a safe process
- High metal removal rate – effective process
- Extremely low burn back rate



Order overview ABIARC gouging electrodes

ABIARC gouging electrodes (DC) pointed

Type		Ampere	Pcs.	Part-No.
4 x 305 mm	(5/32" x 12")	250	50	515.0015
5 x 305 mm	(3/16" x 12")	300	50	515.0016
6.5 x 305 mm	(1/4" x 12")	400	50	515.0017
8 x 305 mm	(5/16" x 12")	500	50	515.0018
9.5 x 305 mm	(3/8" x 12")	600	50	515.0019
13 x 355 mm	(1/2" x 14")	900	50	515.0020

ABIARC gouging electrodes (AC) pointed

Type		Ampere	Pcs.	Part-No.
6.5 x 305 mm	(1/4" x 12")	350	50	515.0023
13 x 355 mm	(3/8" x 12")	450	50	515.0024

ABIARC gouging electrodes (DC) flat

Type		Ampere	Pcs.	Part-No.
10 x 5 x 305 mm		400	50	515.0025
15 x 5 x 305 mm		550	50	515.0026

ABIARC gouging electrodes (DC) jointed

Type		Ampere	Pcs.	Part-No.
9.5 x 430 mm	(3/8" x 17")	600	50	515.0027
13 x 430 mm	(1/2" x 17")	1400	50	515.0028
16 x 430 mm	(5/8" x 17")	1800	50	515.0029
19 x 430 mm	(3/4" x 17")	2000	50	515.0030

ABIARC AL: for lower emissions and best results

These new carbon electrode types, built around a special aluminium core, ensure lower emissions of hazardous substances such as carbon monoxide, chromium, nickel, copper and iron. In addition, ABIARC AL electrodes also reduce general smoke emissions by up to 50 percent with excellent joint quality.



ABIARC AL gouging electrodes (DC)

Type		Ampere	Pcs.	Part-No.
6.5 x 305 mm	(1/4" x 12")	400	50	515.0032.50
8 x 305 mm	(5/16" x 12")	500	50	515.0033.50
9.5 x 305 mm	(3/8" x 12")	600	50	515.0034.50
13 x 355 mm	(1/2" x 14")	900	50	515.0035.50

Coolant recirculators

CR 1000 / CR 1250

For a “cool” welding process ...

In high amperage applications with long welding cycles air-cooled torch systems can reach their limits. This can lead to malfunctions and unnecessary downtime.

The mobile cooling units CR 1000 and CR 1250 are the ideal complement system to equip a power source designed for air-cooled welding with a liquid cooled welding torch. For a permanently “cool” welding process. The devices are characterized by their high cooling performance in a compact design and easy handling.

With a few steps the integrated flow switch¹⁾ for the permanent monitoring of the complete cooling system can be connected to the machine-side connection of the welding torch. Therefore, operation without coolant is not possible and the welding torch as well as the cooling unit are optimally protected.

- High cooling performance in a compact design is ideal for mobile use
- International quick connectors for easy, time-saving installation
- Integrated flow switch for the permanent monitoring of the complete cooling system for protection of the welding torch and the cooling unit – connection set included in delivery
- Exposed tank with coolant level indicator for convenient filling and draining of the coolant
- Overheat protection for pump and motor – for a long life
- Low-weight and sturdy carrying handles for easy transport to the job location
- Splash-proof fuse, main switch and louvers

¹⁾ Operation is also possible without flow switch.



Technical data

Technical data	CR 1000	CR 1250
Heat exchanger	2-row	3-row
Supply voltage	230 V AC / 50 Hz	230 V AC / 50 Hz
Pump 50 Hz	Flow rate Q_{max} 7 l/min Delivery height H_{max} 35 m	Flow rate Q_{max} 7 l/min Delivery height H_{max} 35 m
Pump pressure	3.5 bar	3.5 bar
Cooling capacity	1000 W with H ₂ O 750 W with BTC-15 ²⁾	1250 W with H ₂ O 1050 W with BTC-15 ²⁾
Noise level at 1 m distance	67 dB (A)	67 dB (A)
Weight	14.9 kg	16.7 kg
Dimensions L / W / H	490 / 250 / 410 mm	690 / 250 / 340 mm
Tank capacity	6.0 litres	6.0 litres
Water connection	NW 5 (quick connector)	NW 5 (quick connector)

²⁾ The coolant BTC and BTC NF of ABICOR BINZEL protects liquid cooled welding and cutting torches as well as cooling devices by their very low conductance of < 4 µS/cm against electrolytic corrosion and premature wear.

**Coolant
recirculators cpl.**

Description	Part.-No.
Coolant recirculator CR 1000	850.1001.1
Coolant recirculator CR 1250	850.1051.1

Spare parts

Description	for	Part.-No.
Housing	CR 1000	850.1003.1
Housing	CR 1250	850.1053.1
Cooler double-row	CR 1000	850.1004.1
Cooler three-row	CR 1250	850.1054.1
Bottom part	CR 1000	850.1005.1
Bottom part	CR 1250	850.1055.1
Power cable	CR 1000/1250	850.1006.1
Power switch	CR 1000	850.1007.1
Power switch	CR 1250	850.1056.1
Water tank	CR 1000/1250	850.1008.1
Handle	CR 1000	850.1009.1
Handle cpl.	CR 1250	850.1057.1
Quick coupling (male)	CR 1000/1250	850.1010.2
Quick coupling (female red)	CR 1000/1250	850.1011.1
Quick coupling (female blue)	CR 1000/1250	850.1012.1
Top tank cover	CR 1000/1250	850.1013.1
Bottom tank cover with washer	CR 1000/1250	850.1014.1
Motor holder	CR 1000	850.1015.1
Motor holder	CR 1250	850.1058.1
Motor cpl. with fan	CR 1000/1250	850.1016.1
Fuse holder	CR 1000/1250	850.1018.1
Rubber foot	CR 1000/1250	850.1019.4
Fan vane cpl.	CR 1000/1250	850.1020.1
Screw set for housing	CR 1000	850.1021.20
Screw set for housing	CR 1250	850.1067.20
Hose set 2 m with 10 clamps	CR 1000/1250	850.1022.1
Connection nipple G1/4"	CR 1000/1250	850.1023.2
Fine-wire fuse 3 A	CR 1000/1250	850.1024.10
Control lead cpl. (flow control)	CR 1000/1250	850.1026.1
Flow control	CR 1000/1250	850.1059.1
Y-Distributor cpl.	CR 1000/1250	850.1027.2
Control socket 2-pole	CR 1000/1250	850.1060.1
Control plug 2-pole	CR 1000/1250	850.1061.1
Sealing kit for pump	CR 1000/1250	850.1072.1

Our product range:

■ MIG/MAG

- Welding torches
- Machine and special torches
- Push-Pull welding torches
- Fume extraction torches
- Central adapter system

■ WIG

- Welding torches
- Machine and special torches

■ PLASMA

- Cutting torches
- Welding torches
- Machine and special torches

■ Robotic Peripheral Equipment

- Robot torches
MIG/TIG/PLASMA
- Robot mount CAT2/iCAT
- Torch change system
ATS-Rotor
- Tool change system WWS
- Wire cutting station DAV
- Torch cleaning stations
BRS-LC, BRS-CC and BRS-FP
- Wire feeding station APD-MF

■ Welding Accessories

- Coolers
- Welding cable plug and socket
- Anti spatter Spray and paste
and so on ...



Alexander Binzel Schweisstechnik GmbH & Co. KG
Kiesacker · 35418 Buseck · GERMANY
T +49 64 08 / 59-0
F +49 64 08 / 59-191
info@binzel-abicor.com

www.binzel-abicor.com

